

# Magneti Marelli Dinoplex C AEC101 CA/CB/D/DA/E/EA Circuit Diagram

PCB version 740239-10, 740311-10

V 1.6 11/2008, info@dinoplex.org, www.dinoplex.org.

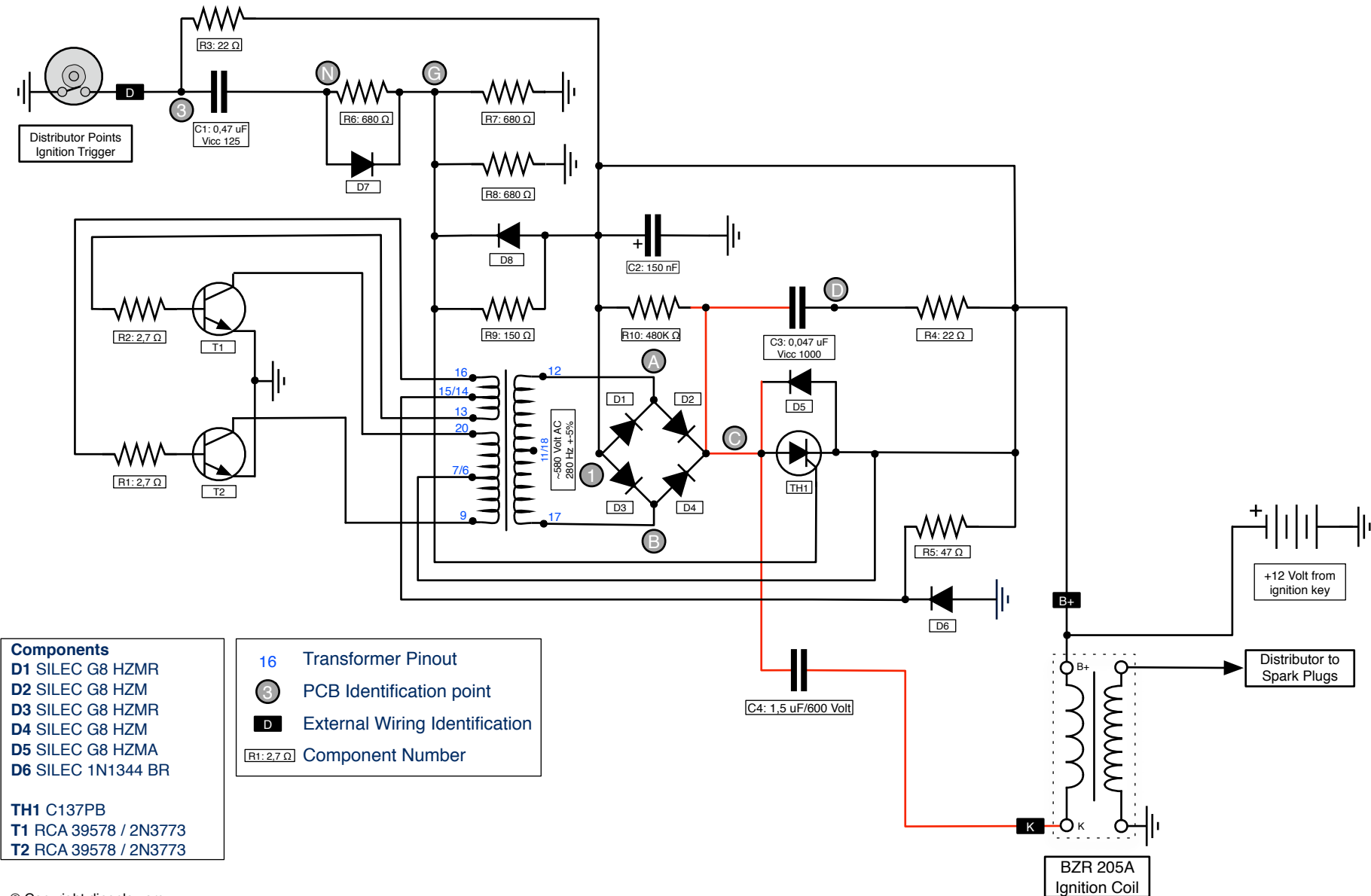

- Components**
- D1 SILEC G8 HZMR
  - D2 SILEC G8 HZM
  - D3 SILEC G8 HZMR
  - D4 SILEC G8 HZM
  - D5 SILEC G8 HZMA
  - D6 SILEC 1N1344 BR
- TH1 C137PB  
 T1 RCA 39578 / 2N3773  
 T2 RCA 39578 / 2N3773

- 16 Transformer Pinout
- 3 PCB Identification point
- D External Wiring Identification
- R1: 2.7 Ω Component Number