

Magneti Marelli Dinoplex AEC 101 External Wiring
V 1.2 info@dinoplex.org 12/2008, www.dinoplex.org

Dinoplex Wiring to Switch

- 1 B+ (12V from ignition/Coil B+ to Dinoplex B+)
- 2 K (to Coil - 'K')
- 3 D (from distributor points / to tacho)
- 4 to Tacho (units from 1969-1970)

External Wiring

- 1 B+ (12V from ignition/Coil B+ to Dinoplex B+)
- 2 K (to Coil - 'K')
- 3 A (to ballast resistor for 'Emergenza' mode)
- 4 D (from distributor points)

Dinoplex C AEC 101 C/CA with Emergenza Switch (1968-1969)

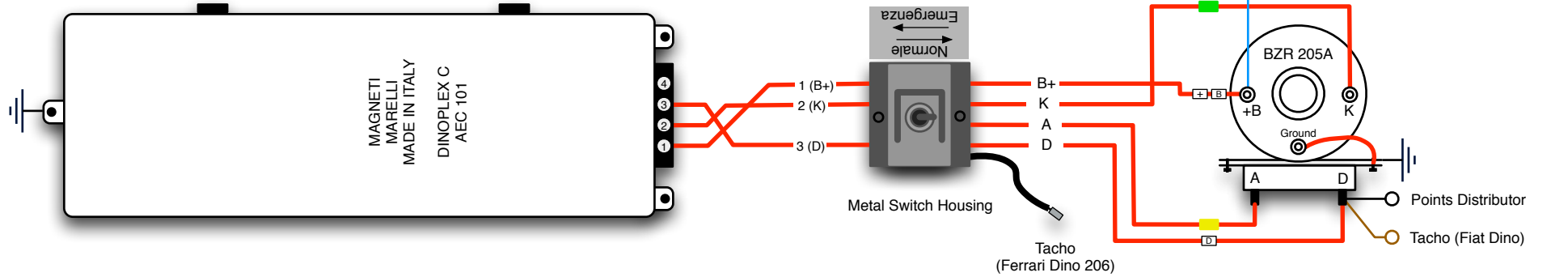

Dinoplex C AEC 101 CA/CB/D/DA with Emergenza Switch (1969-1970)

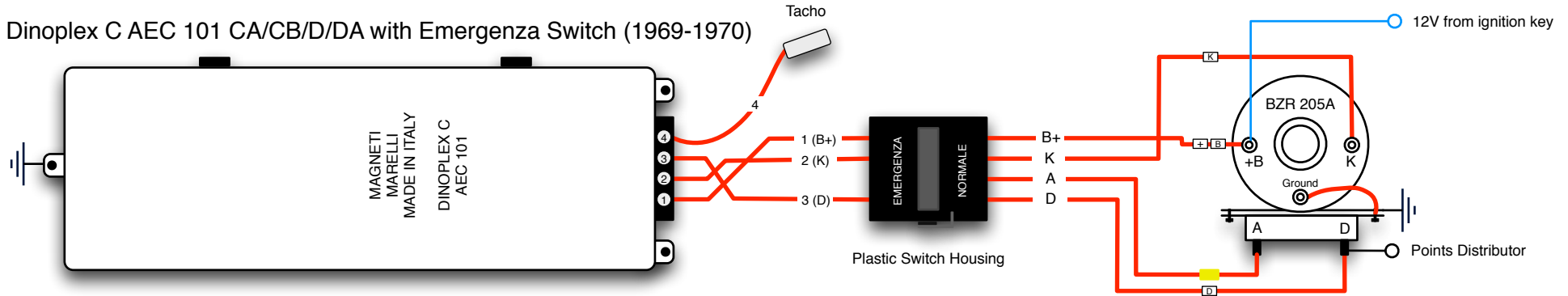

Dinoplex AEC 101 E/EA for 12 cylinder engines (two units are required)

