

Magneti Marelli Dinoplex AEC 103A

Ferrari Dino 246 Wiring, '70 Europe, two terminal connector

V 1.0 12/2010, Copyright www.dinoplex.org, info@dinoplex.org

This wiring diagram applies to a Ferrari Dino without emission control equipment (M and early E Series).

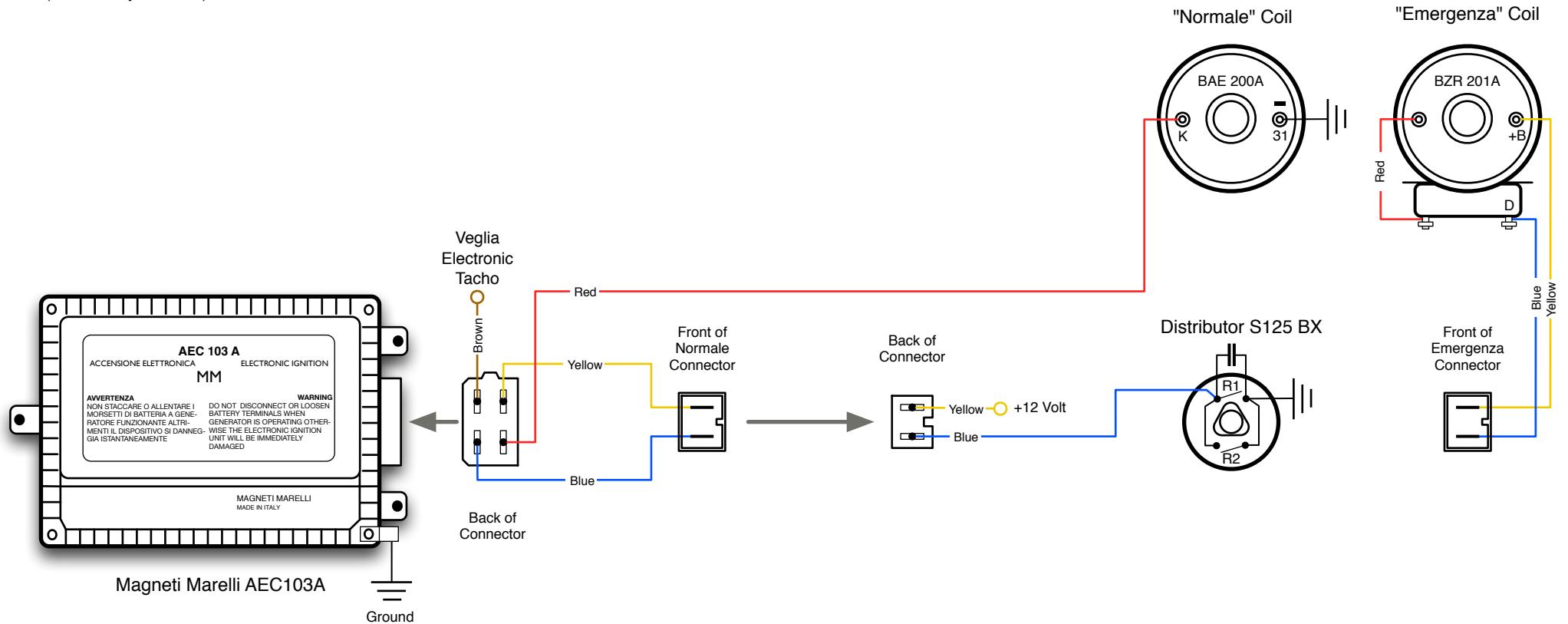

AEC103A Connector, Front

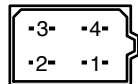

1. +12V from ignition key, yellow wire
2. to ignition coil terminal 'K', red wire
3. 'D' from distributor points R1, blue wire
4. to Veglia tachometer, brown wire