

Magneti Marelli Dinoplex AEC 103A

Ferrari Dino 246 Wiring, '72 US, three terminal connector

V 1.0 12/2010, Copyright www.dinoplex.org, info@dinoplex.org

This wiring diagram applies to US cars fitted with an air pump for smog regulation. The **Air Pump Relay Controller** device activates the air pump via the air pump clutch from zero to 4200 RPM, above that the air pump is disengaged to avoid damages due to the high RPM. The **Anti Hop device** adds the retarded points set R2 to R1 when the accelerator pedal is not pressed (signaled by a microswitch on one Weber carb throttle link), an integrated timer makes sure that when the accelerator pedal is not pressed for just a short amount of time (as example when switching gears or decelerating) the retard function is not activated and the car won't 'hop'.

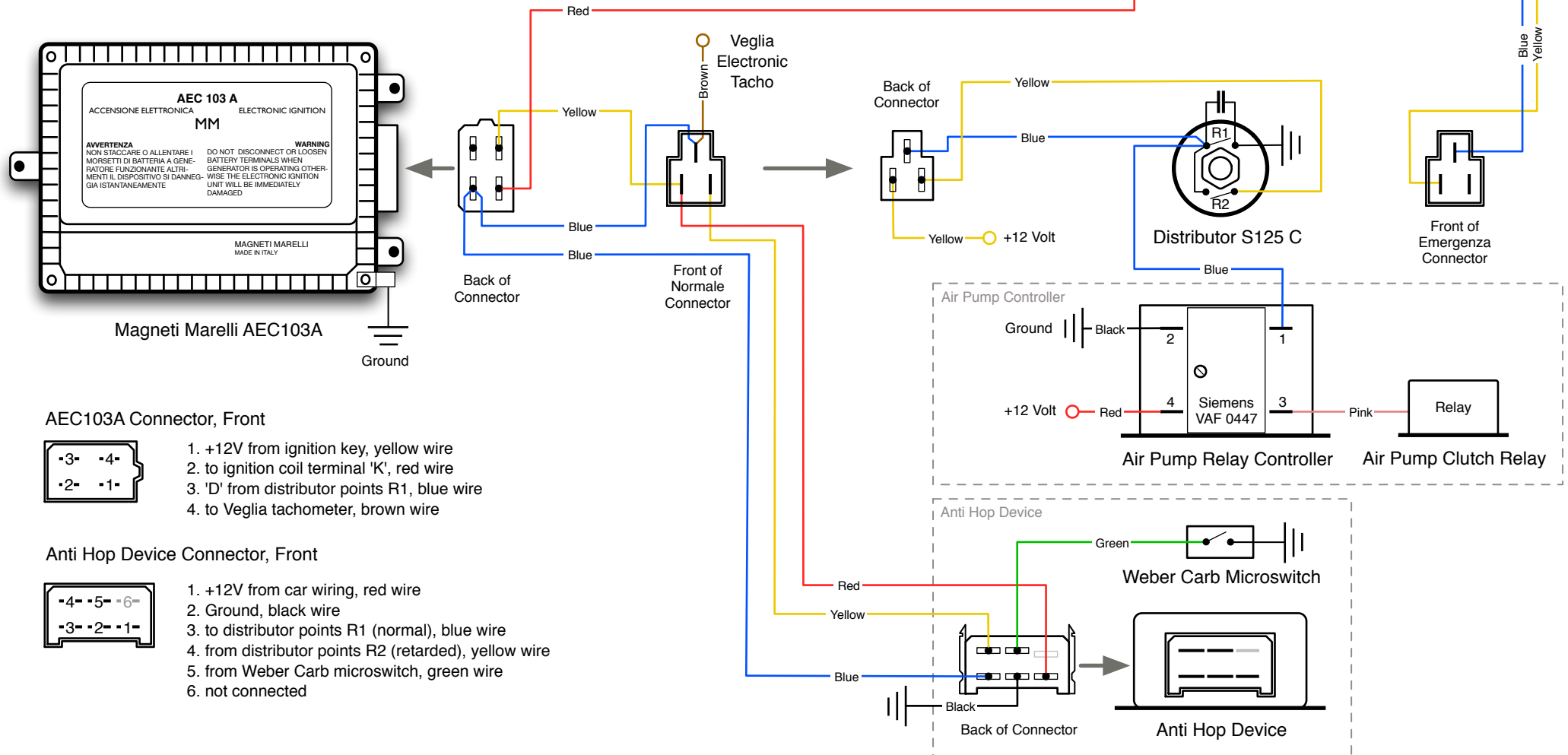

AEC103A Connector, Front

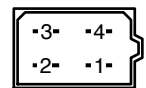

1. +12V from ignition key, yellow wire
2. to ignition coil terminal 'K', red wire
3. 'D' from distributor points R1, blue wire
4. to Veglia tachometer, brown wire

Anti Hop Device Connector, Front

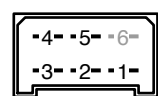

1. +12V from car wiring, red wire
2. Ground, black wire
3. to distributor points R1 (normal), blue wire
4. from distributor points R2 (retarded), yellow wire
5. from Weber Carb microswitch, green wire
6. not connected