

**Lumenition Optronic Performance Setup for Fiat Dino, Ferrari Dino 246 and Lancia Stratos
Marelli Magneti S125 AX/BX/C distributor converted to optical pickup**

V 1.2 info@dinoplex.org 09/2009
www.dinoplex.org

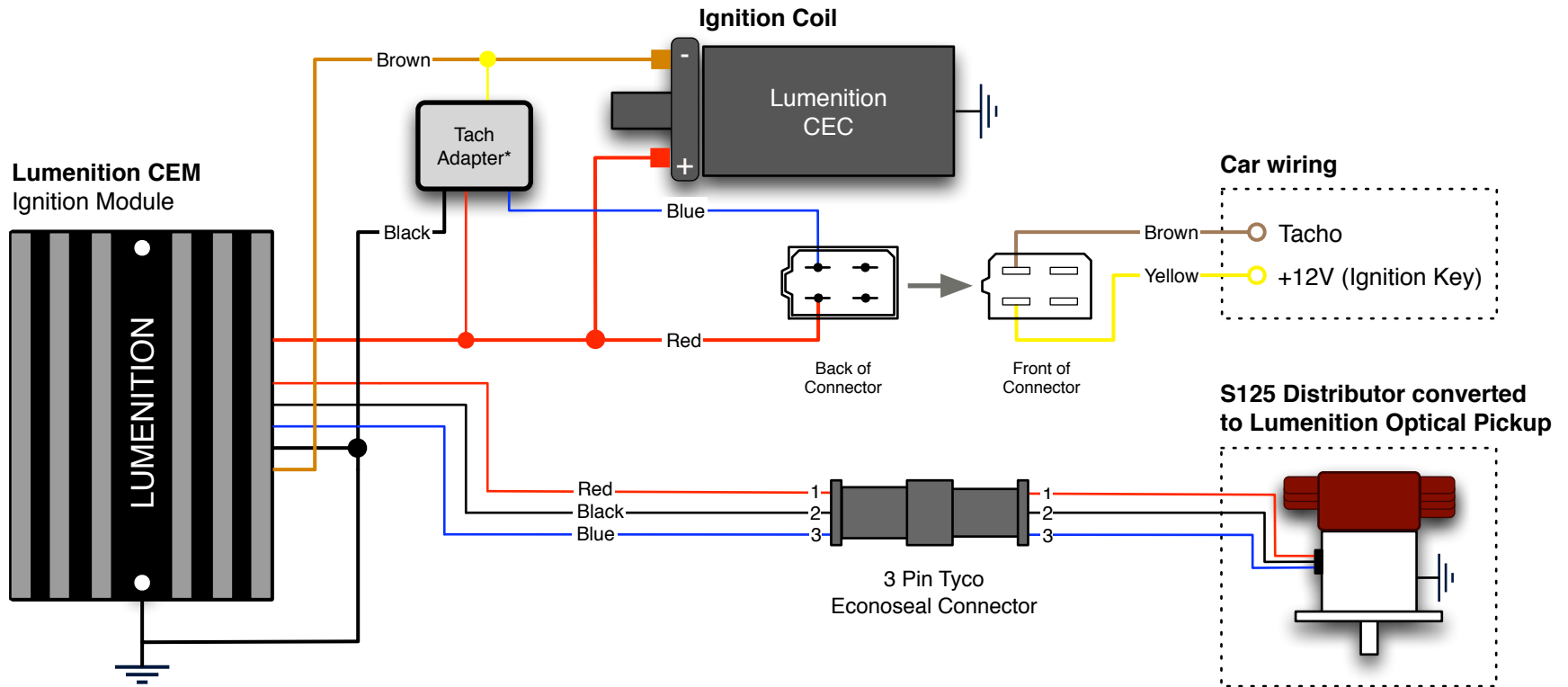

This setup is a replacement for a Dinoplex C or AEC 103A, The setup based on a Lumenition Optronic Performance constant energy inductive ignition (CEM) combined with an optical pickup (CET150) and coil (CEC). The Lumenition Optronic Performance optical pickup CET150 requires an adaption kit containing a trigger wheel (chopper) such as the F425 or F009. Both of the kits need to be modified, as the included F425 chopper is slightly too large and the F009 chopper a bit too small.

*To drive the electronic Veglia tacho, a tacho adapter for converting the coils high voltage impulse into a +12 volt square wave signal is required. It is recommended to install an active electronic tacho adapter, such adapters can be identified by an additional +12 volt wire.