

Magneti Marelli Dinoplex AEC 103A to MSD 6AL-2 Conversion Ferrari Dino 246 Wiring Adaption, two terminal connector

V 1.1 07/2014, Copyright www.dinoplex.org, info@dinoplex.org

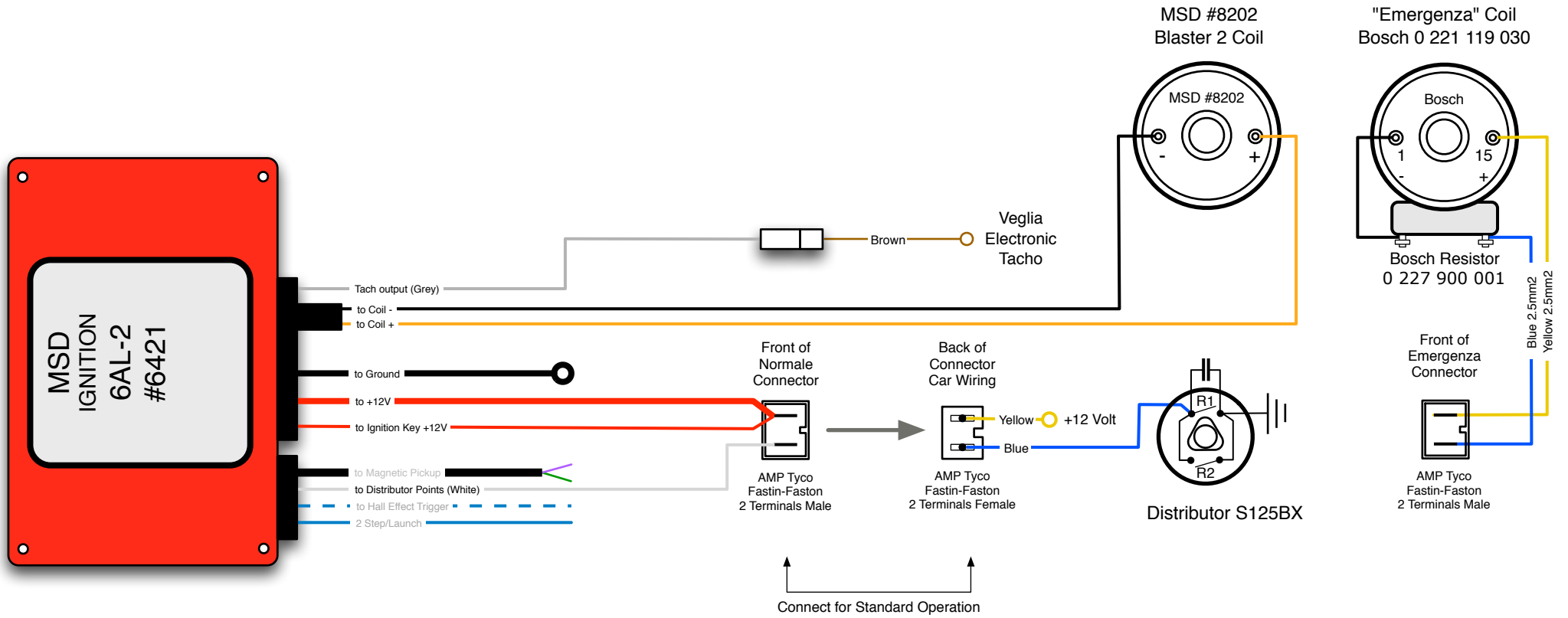

Rev Limiter Setting (7800 RPM)

Set "MAX REV LIM" dials to:

1000: 7

100: 8

Cyl: 6